

FEATURES

- 30A to 80A continuous current capacity
- Automotive - oriented design
- Fully standardized QC size and layout
- Plastic cover for rough environment protection

TYPICAL AUTOMOTIVE APPLICATIONS

- Head lights
- Fog lamp
- Signal horn
- Blower motor control
- Starter relay
- Radiator cooling fan
- Power window
- ABS system
- Start bypass relay



CONTACT DATA

HG4185A

Form		1 Form A (1H, 1HJ)	1 Form C (1Z)
Max. Switching Current	Make	120A	NO120A/NC 45A
	Break	40A	NO40A/NC 30A
Material		Default = AgNi10 (See Page 2 for options and RoHS Compliance)	
Initial Contact Resistance		100 mΩ max. at 0.1A, 6VDC	
Max. Switching Voltage		See Curve 1, current dependent	
Max. Continuous Current		30A	NO30A/NC 30A
Min. Load		0.1A, 12VDC	
Service Life	Mechanical	10 ⁷ ops.	
	Electrical	2 x 10 ⁵ ops, see Note 4	

HG4185B

Form		1 Form A (1H, 1HJ)	1 Form C (1Z)
Max. Switching Current	Make	120A	NO120A/NC 45A
	Break	60A	NO60A/NC 40A
Material		Default = AgCdO (See Page 2 for RoHS Compliant materials)	
Initial Contact Resistance		100 mΩ max. at 0.1A, 6VDC	
Max. Switching Voltage		See Curve 1, current dependent	
Max. Continuous Current		60A	NO60A/NC 40A
Min. Load		0.5A, 12VDC	
Service Life	Mechanical	10 ⁷ ops.	
	Electrical	2 x 10 ⁵ ops, see Note 4	

HG4185C

Form		1 Form A (1H)	1 Form C (1Z)
Max. Switching Current	Make	240A	NO240A/NC 180A
	Break	80A	NO80A/NC 60A
Material		Default = AgSnOInO (See Page 2 for options and RoHS Compliance)	
Initial Contact Resistance		100 mΩ max. at 0.1A, 6VDC	
Max. Switching Voltage		See Curve 2, current dependent	
Max. Continuous Current		80A	NO80A/NC 60A
Min. Load		0.5A, 12VDC	
Service Life	Mechanical	10 ⁷ ops.	
	Electrical	10 ⁵ ops, see Note 4	

HG4185A/B/C

COIL DATA

Coil Voltage Code	Nominal Voltage (VDC)	Resistance (Ω) $\pm 10\%$	Must Operate Voltage max. (VDC)	Allowable Voltage (VDC)	Must Release Voltage min. (VDC)
006	6	22	3.6	10.1	0.6
012	12	90	7.2	20.5	1.2
024	24	330	14.3	39.1	2.4

CHARACTERISTICS

Operate Time	7 ms. typical
Release Time	2 ms. typical
Insulation Resistance	100 M Ω , at 500 VDC, 50%RH
Dielectric Strength	500 Vrms, 1 min.
Shock Resistance	20 g, 11ms.
Vibration Resistance	10-40Hz: DA 1.27mm; 40-70Hz: 5 g; 70-100Hz: DA 0.5mm; 100-500Hz: 10 g.
Drop Resistance	1 M height drop on concrete
Power Consumption	1.6W, unsuppressed; 1.81W, with resistor
Ambient Temperature	-40°C to 125°C operating; -40°C to 155°C storage
Weight	35 g, approx.

ORDERING DESIGNATION

Example:	HG4185	C /	012	R -	1H	9	-1	S	-P
Model									
Rating Code A: 40A; B: 60A; C: 80A									
Coil Voltage Code									
Paralleled Component D: Diode* (+) 85~86 (-); Nil: Nil; R: Resistor;	DR: Diode Reversed* (-) 85~86 (+) BD: Bidirectional Diode								
Contact Form 1H: 1 Form A; 1HJ**: 1 Form A with Double 87 Terminals; 1Z: 1 Form C									
Mounting Version Nil: Plug-In; 4: PCB; 9: Molded Bracket;	9M1: Metal Bracket; 9S2: Skirted Cover + Bent Metal Bracket 9M2: Bent Metal Bracket; 9S1: Skirted Cover + Metal Bracket;								
Version None: Dust Cover	1: Sealed (Not available for HG4185C nor any Metal Bracket mounting)								
Contact Material None: Default*** N: AgNi10	A: AgNi0.15 C: AgCdO (not RoHS Compliant - not available with "- P" Option) S: AgSnOInO								
P: RoHS Compliant (Lead-free)									

*: See wiring diagrams

** : See wiring diagrams, and available for HG4185A and HG4185B only.

***: See specific default contact material in Contact Data tables

REFERENCE CURVES

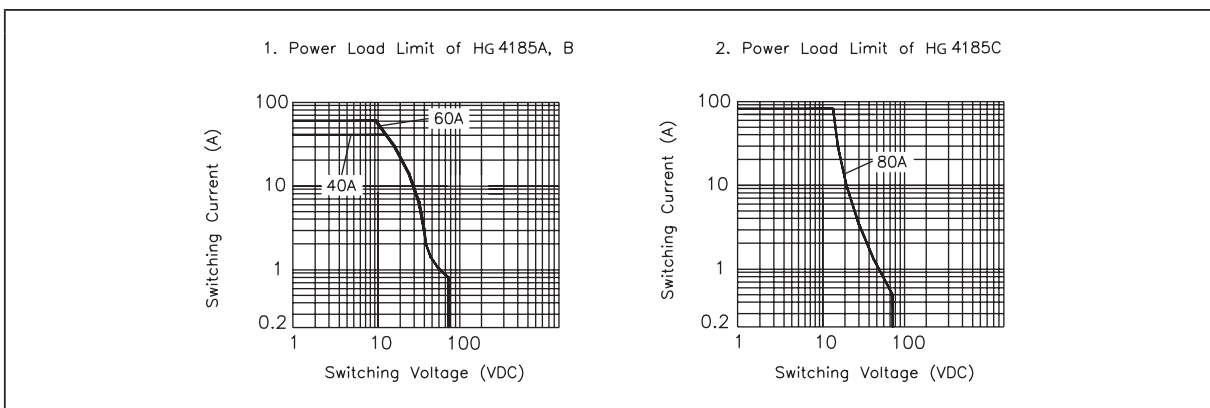

HG4185A/B/C

OVERALL DIMENSIONS, OPTIONAL COVERS, TERMINAL LAYOUTS, MOUNTING HOLES AND WIRING DIAGRAMS (mm)

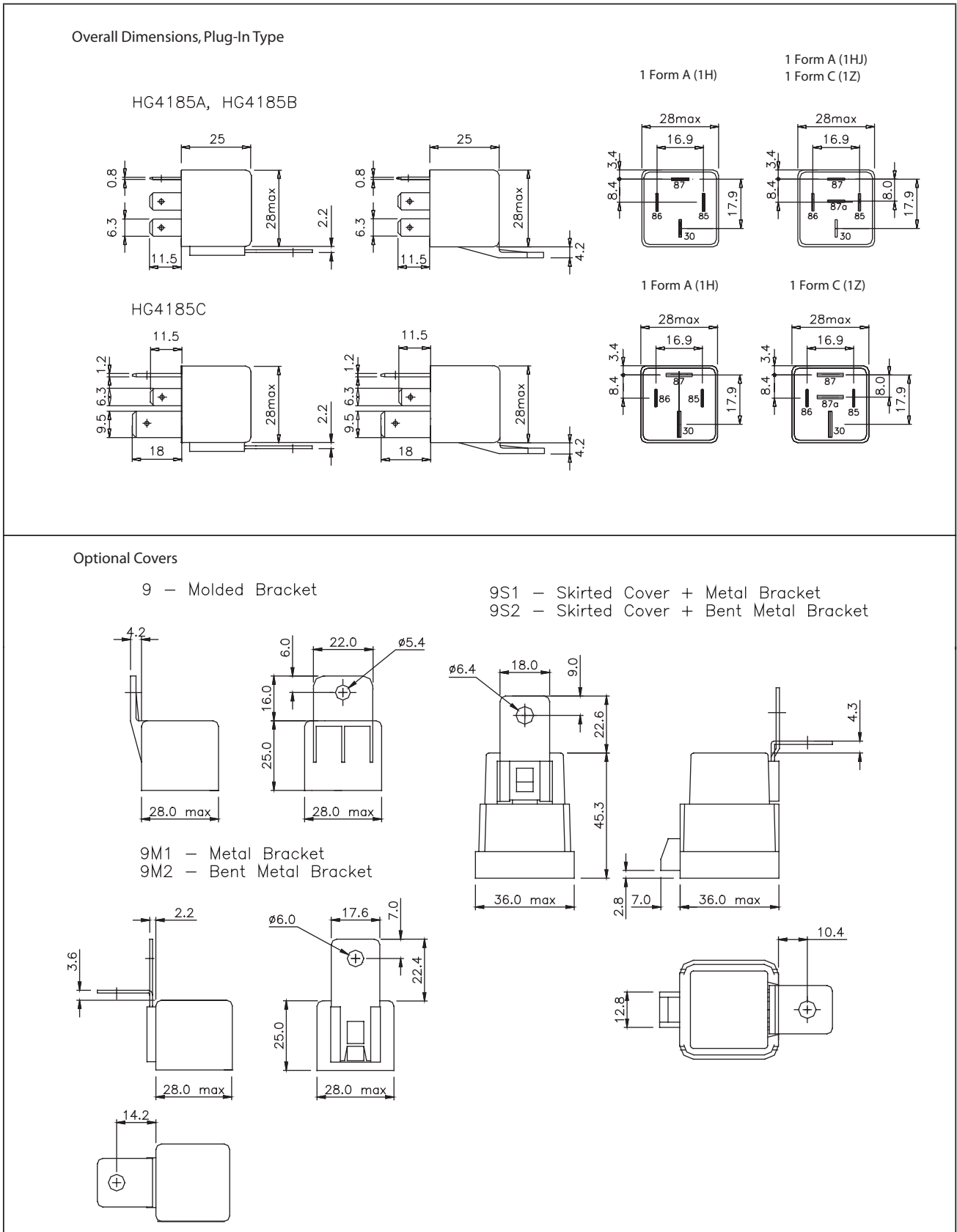

HG4185A/B/C

Overall Dimensions, PCB Type

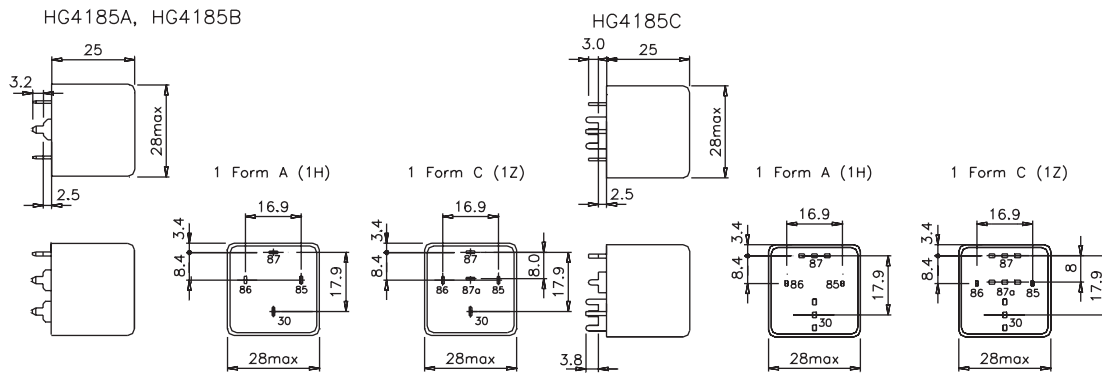

PCB Type Mounting Holes (Bottom View)

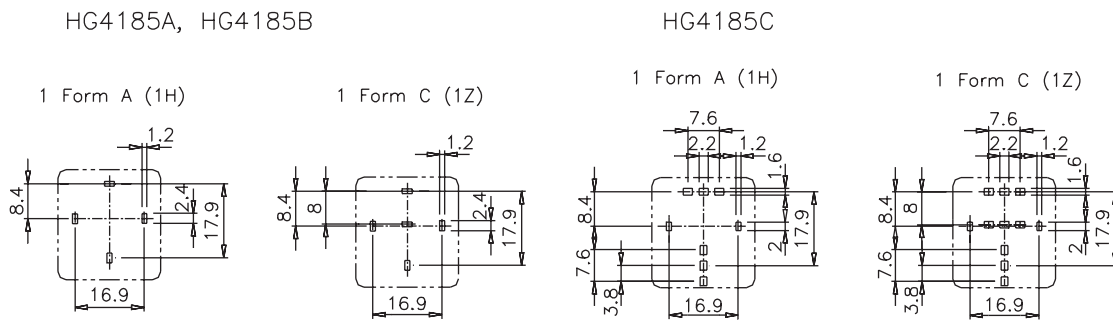

Wiring Diagrams

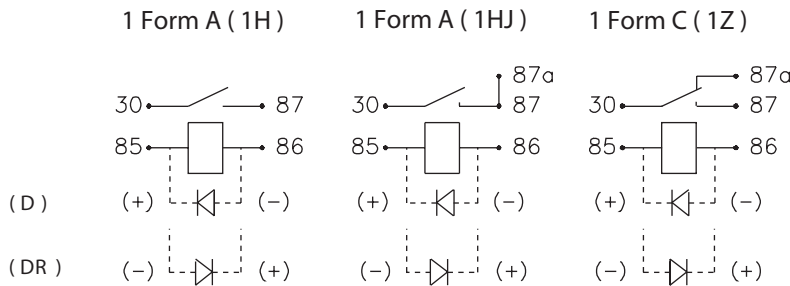

NOTES

1. All parameters, unless otherwise specified, are measured at ambient temperature 23°C.
2. Maximum make current refers to inrush current of lamp load.
3. At ambient temperature of 85°C, maximum allowable voltage should be reduced to 72%.
4. Electrical life obtained at resistive or inductive load at 20A, 15 VDC for HG4185A; 40A, 15VDC for HG4185B; 80A, 15VDC for HG4185C with suitable arc-suppression circuit attached with operating frequency of 1 ops/sec.
5. Custom-made services available with operational quantity. Please let us know your special requirements.
6. Specifications subject to change without prior notice.

Willow Technologies Limited
 Shawlands Court, Newchapel Rd.,
 Lingfield, Surrey,
 England. RH7 6BL.
 Tel: 00 44 (0) 1342 835234
 Fax: 00 44 (0) 1342 834306
 email: sales@willow.co.uk
 http://www.willow.co.uk